



TECHNICAL SPECIFICATION

Mainly suitable for indoor lighting, simple shape, simple installation method, beautiful and generous. Made of high quality STCH-1616 aviation aluminum with silver oxidized surface, matching push-on PC mask. Push-in plug. Surface snap mount, matching stainless steel mounting clip

FEATURES

- Extruded Aluminum Construction
- Anodized matte finish
- Available In 39.37" (1m) and 78.74" (2m) Sections
- Walkover rated

DIMENSIONS

- Length: 39.37" (1m) / 78.74" (2m)
- Width (External): 0.62" (16mm)
- Width (Internal): 0.41" (10.6mm)
- Height: 0.62" (16mm)

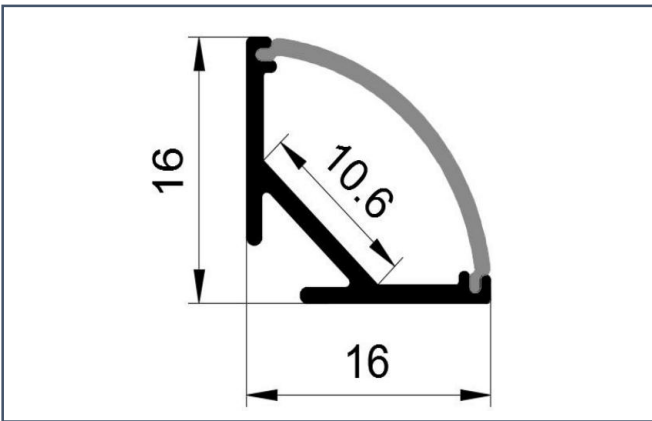

ACCESSORY

FROST WHITE LENS



END CAP PAIR

MOUNTING CLIP



INSTALLATION STEP SCHEMATICS

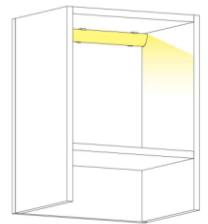
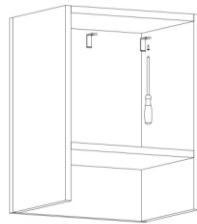

Step 1: Secure the mounting clip Step 2: Install the LED strip, plug, PC cover, fix the light body Step 3: Connect the driver and turn on the power supply

1. Series

STCH-1616 = Salt Channel 1616

2. Length

1 = 1m (39.37")
2 = 2m (78.74")

3. Lens

FW = Frost White

4. End Cap

EC = End Cap*

*End Cap Included